

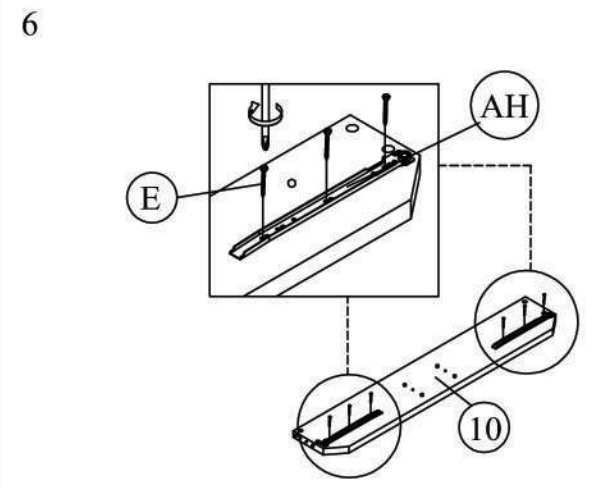

1 A NAGY ÉS KIS FIÓK ÖSSZESZERELÉSEKOR AZ 1-5. LÉPÉSEK SZERINT JÁRJON EL

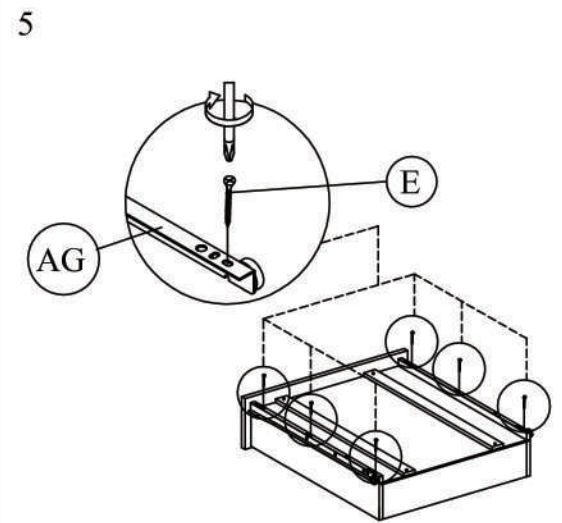

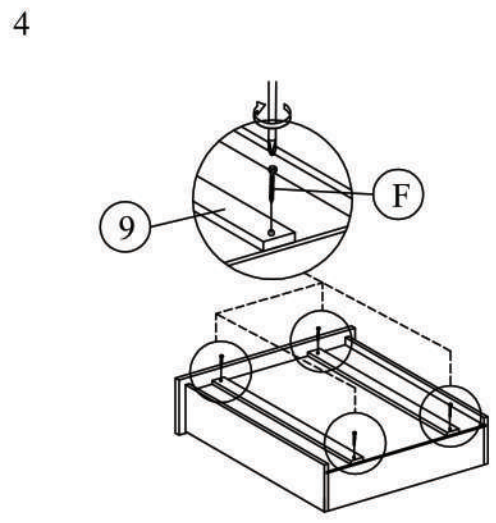

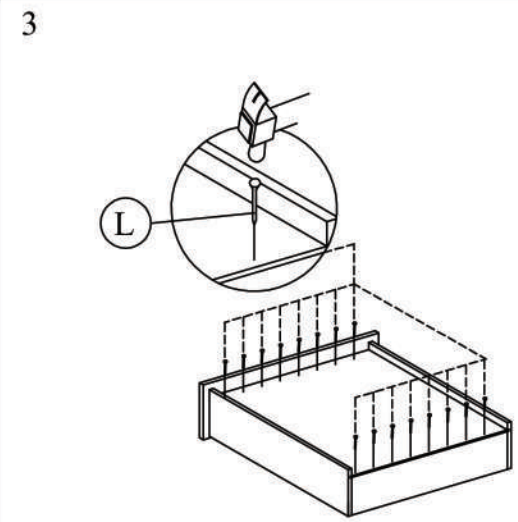
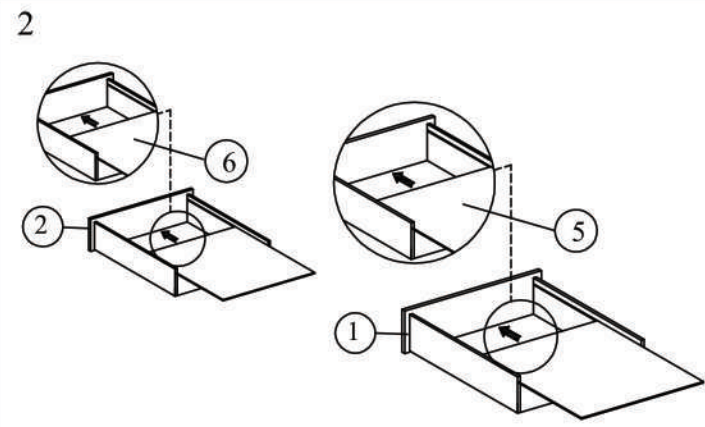
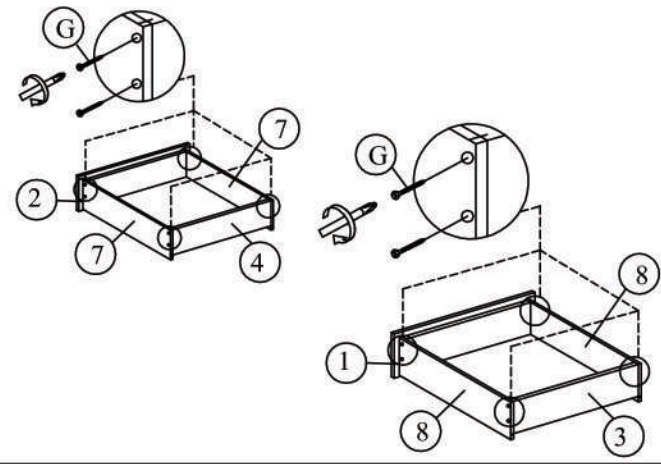
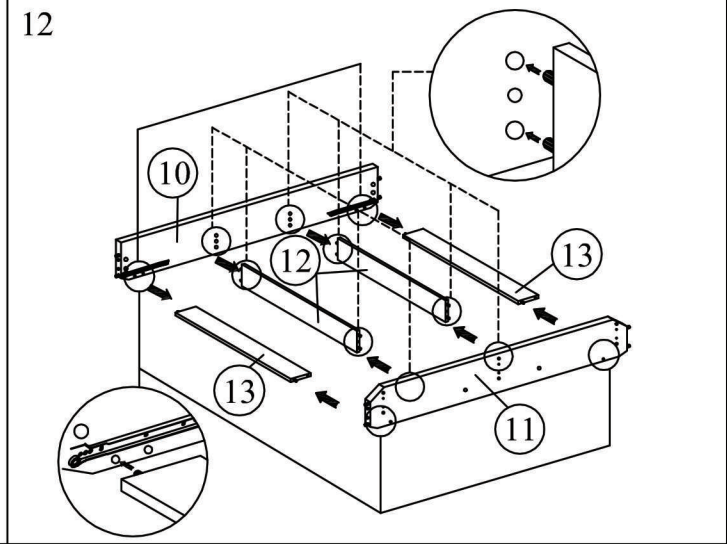
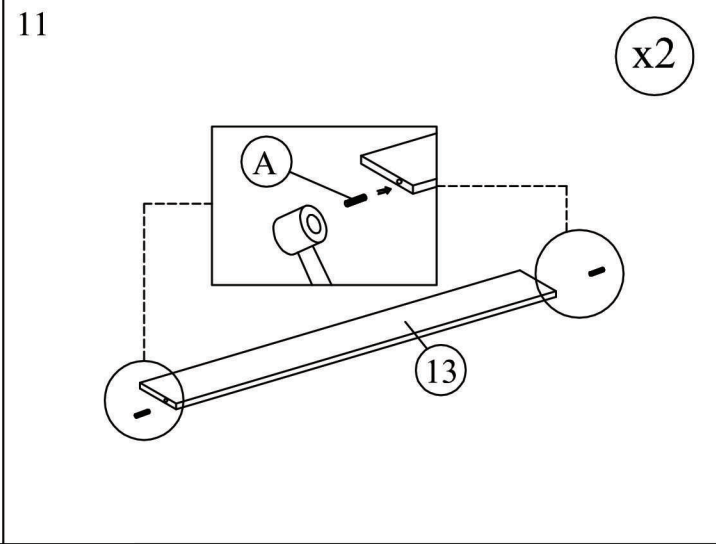
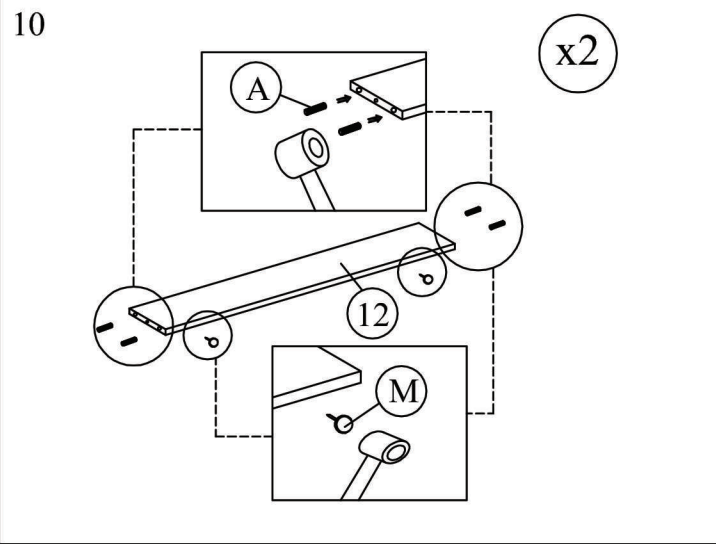
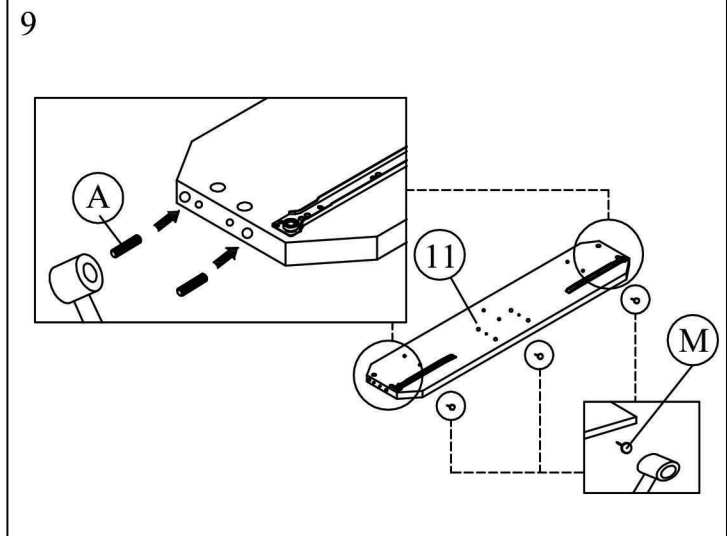
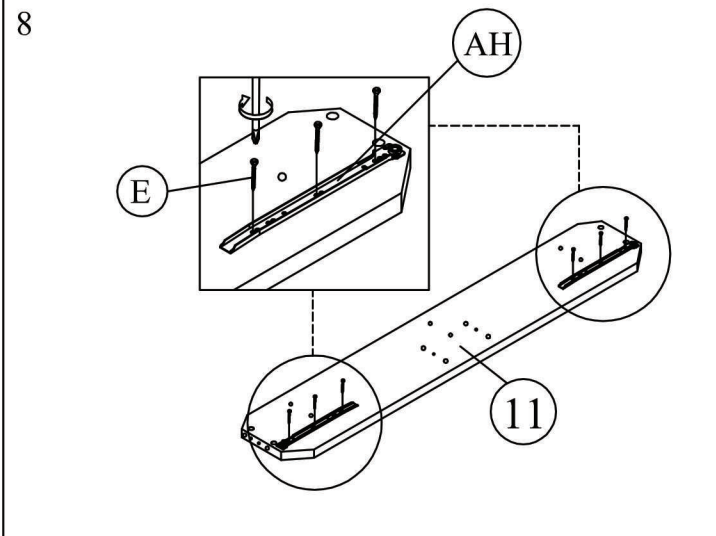
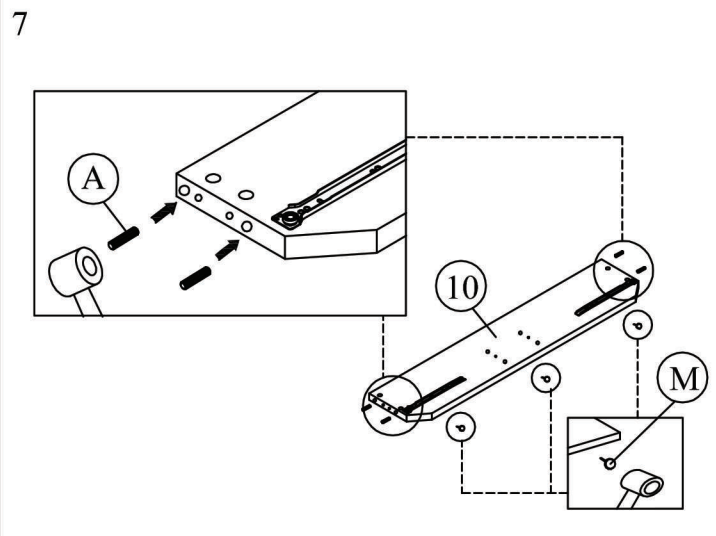
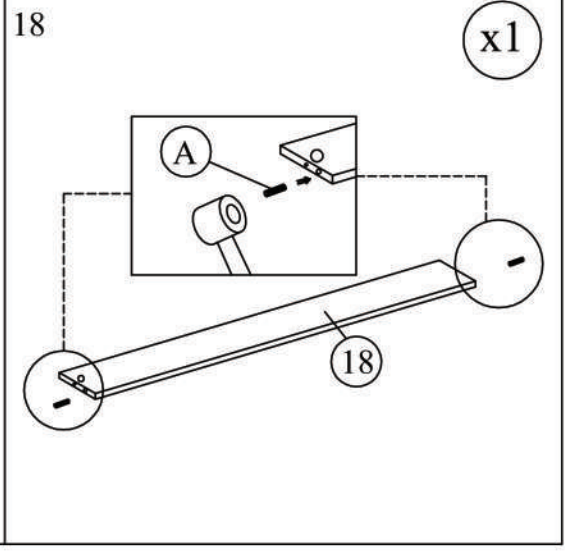
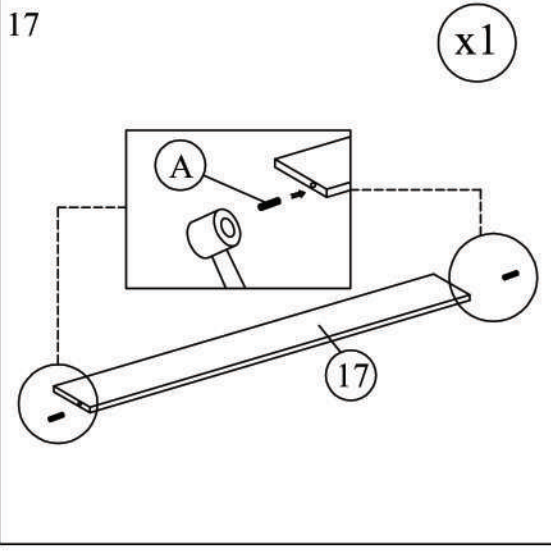
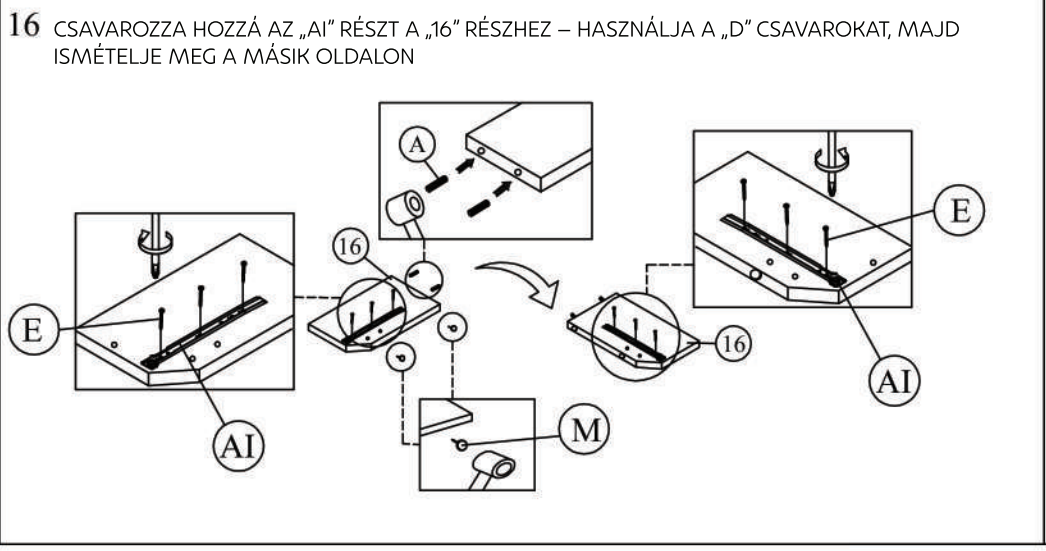
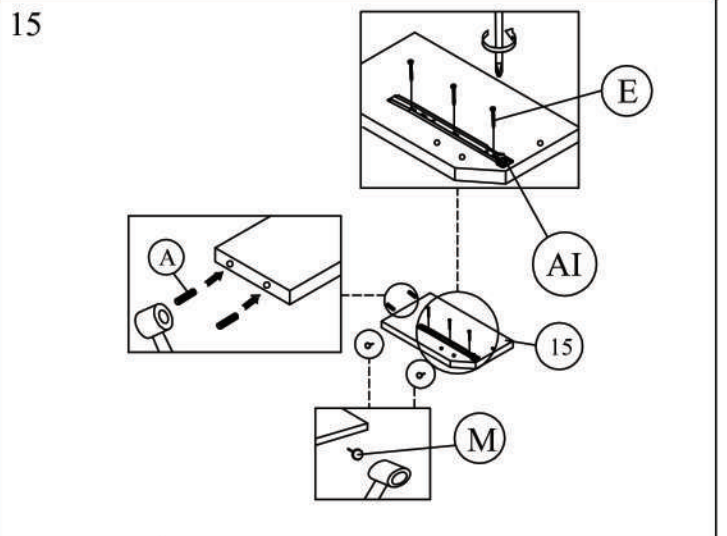
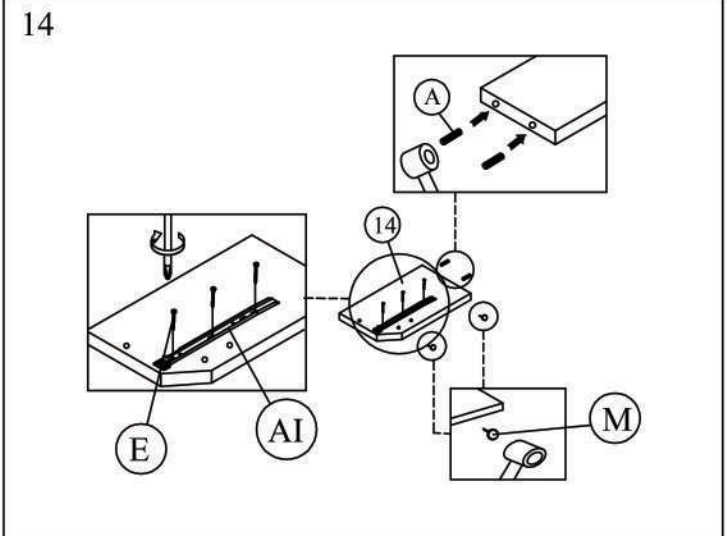
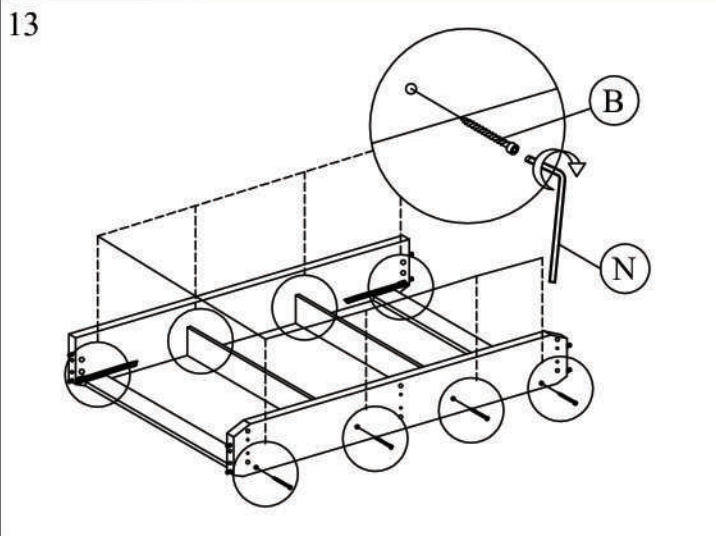

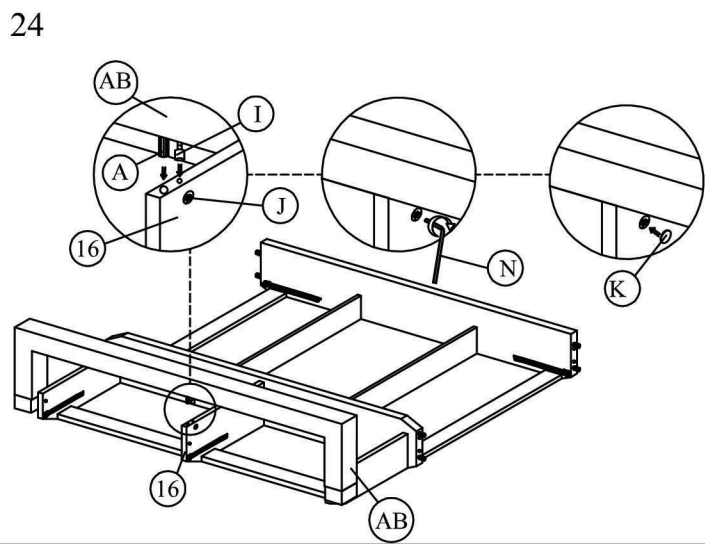
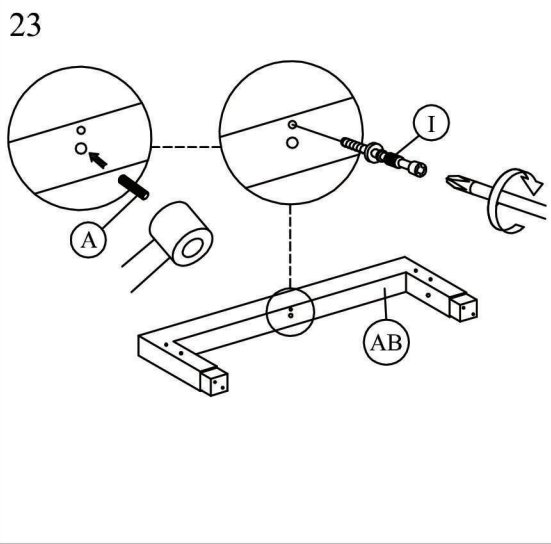
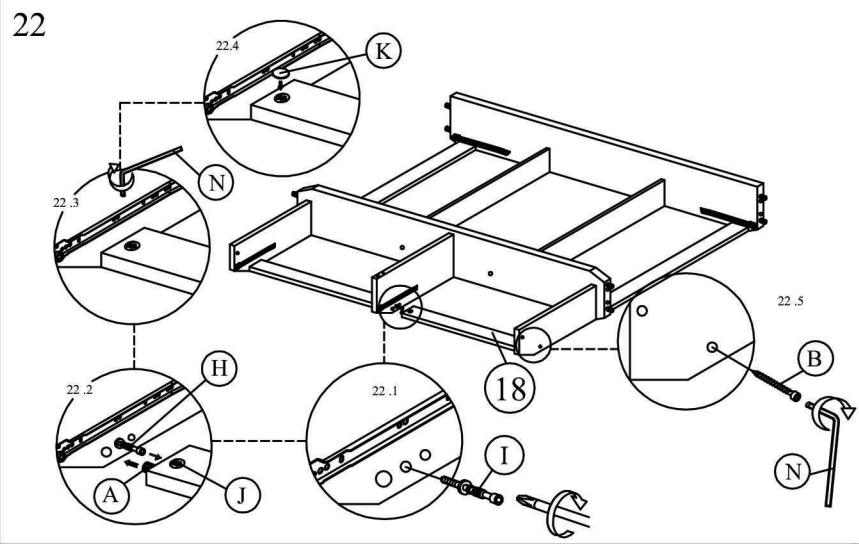
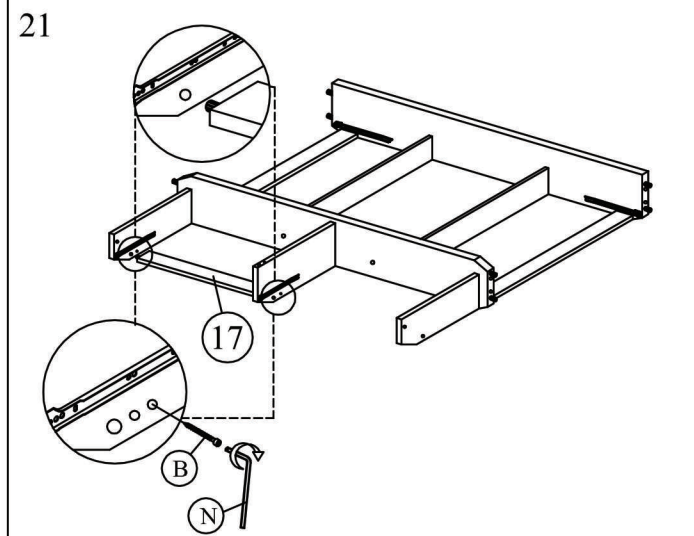
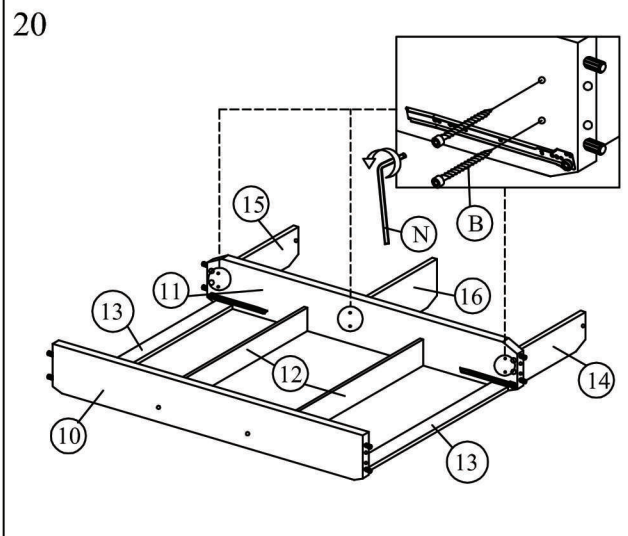
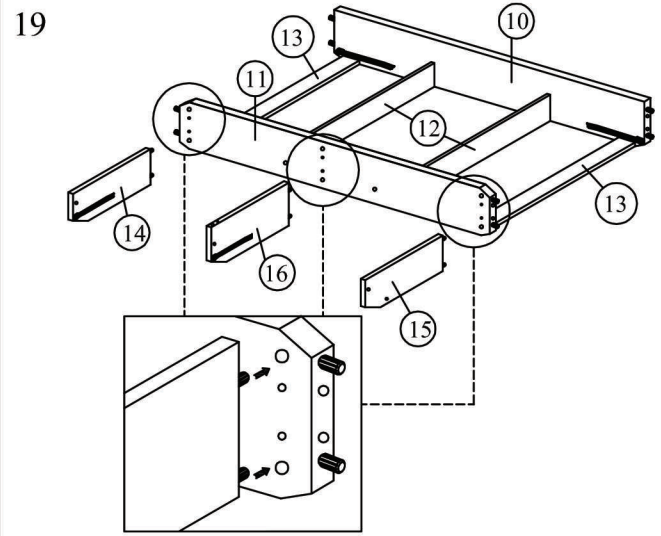

25

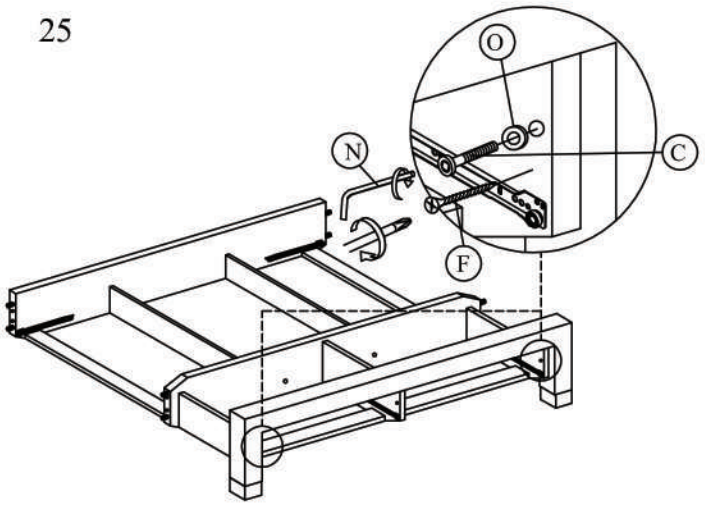

26

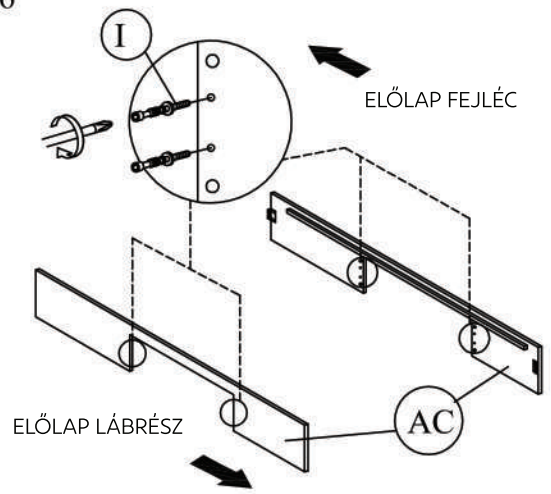

27

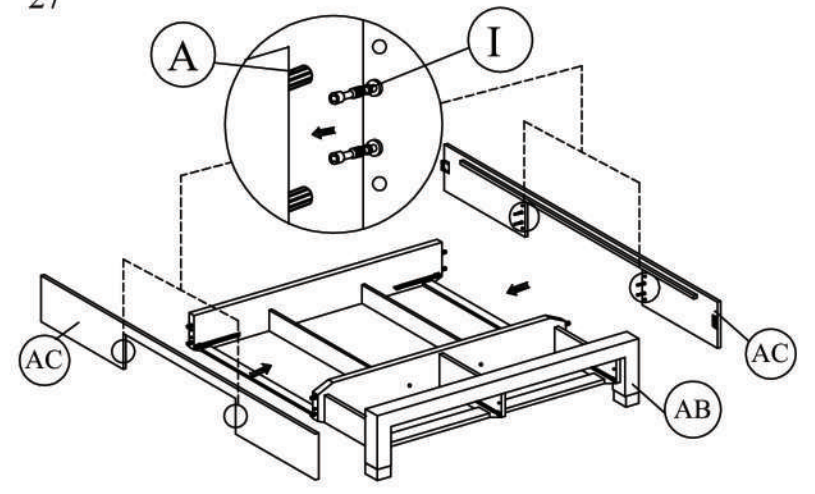

28

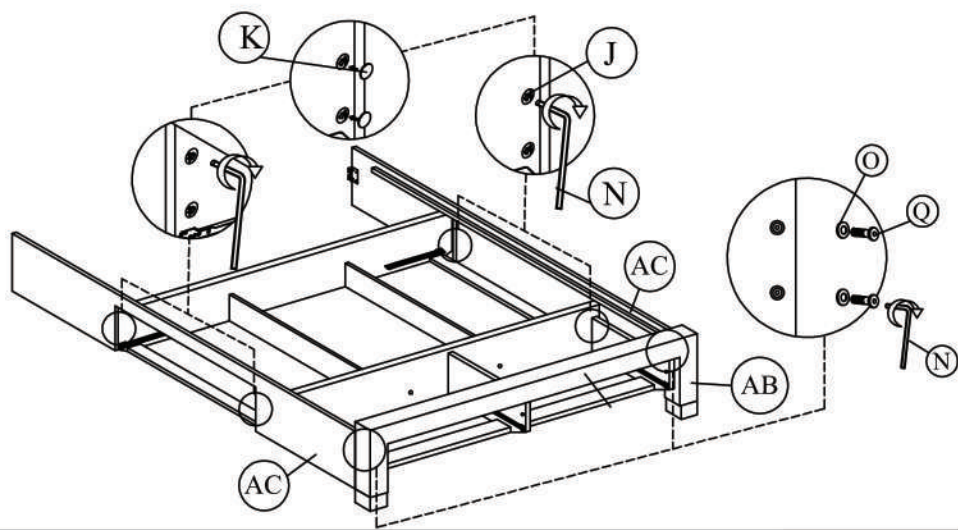

29

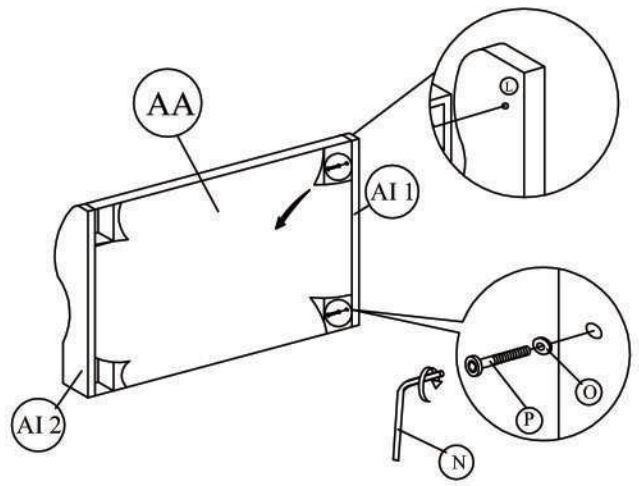

30

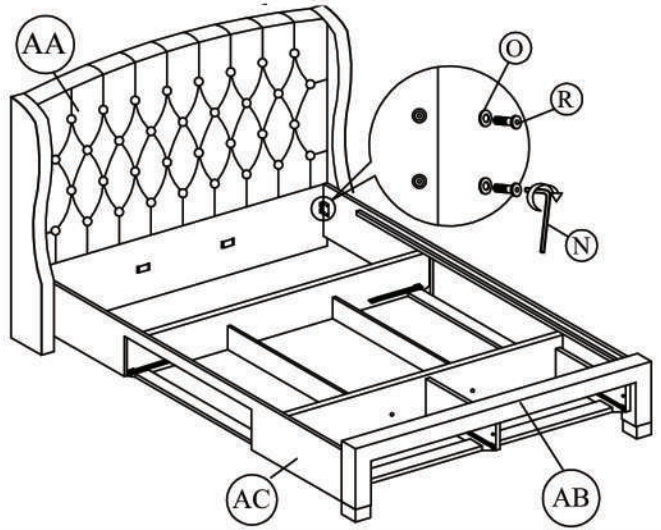

31

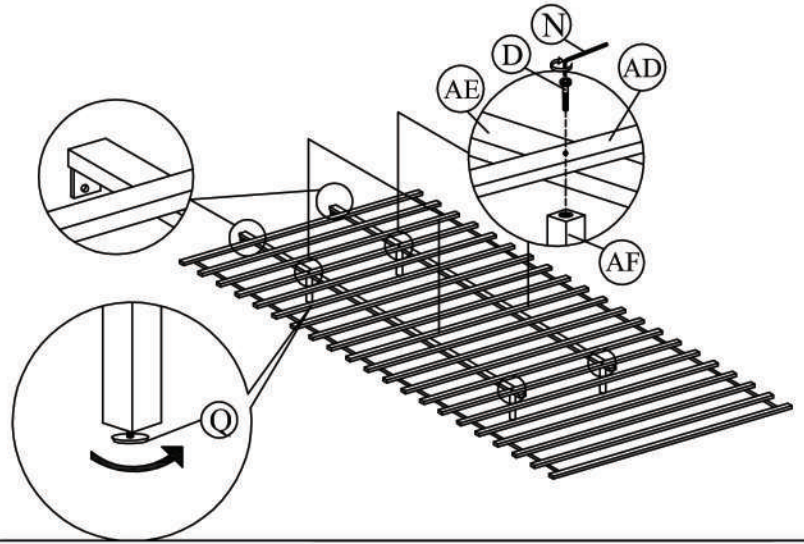

32

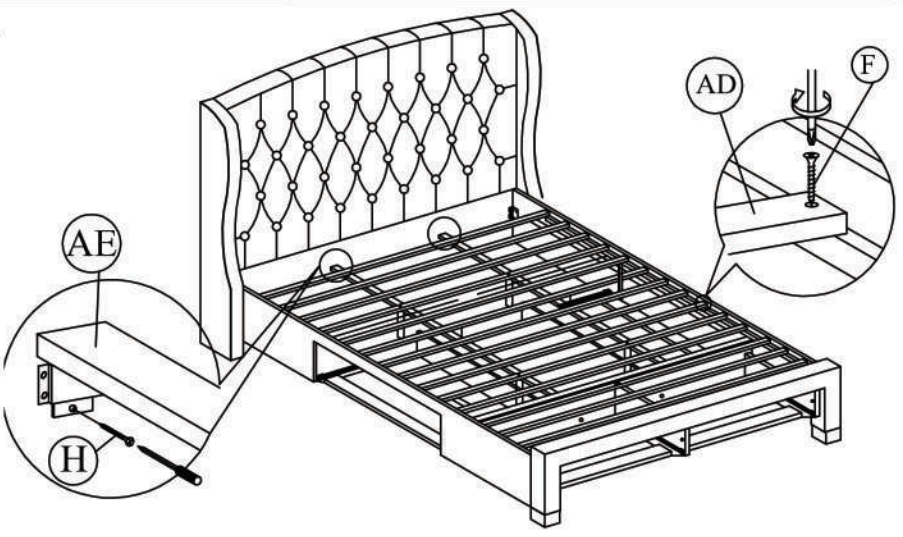

33

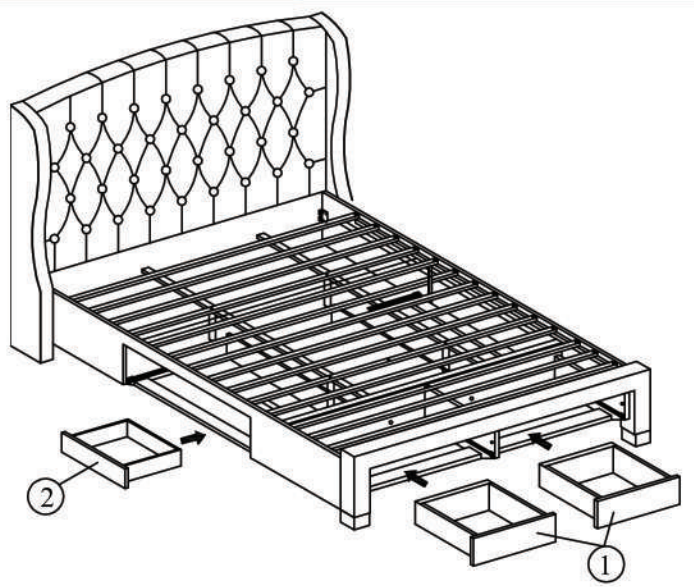

FIGYELEM! HA AZ ÁGYÁT ODÉBB SZERETNÉ HELYEZNI, EGY MÁSIK SZEMÉLY(EK) SEGÍTSÉGÉVEL EMELJE MEG, NE HÚZZA A PADLÓN ÁT!